

Model JI-300 I2C Host Adapter

User's Manual



TABLE OF CONTENTS

1.	INTRODUCTION	4
1.1	Front Panel Description	5
1.2	Rear Panel Description	5
2.	GETTING STARTED	6
2.1	Software Installation	6
2.2	Hardware Setup	6
2.3	Communications Check	6
2.4	I2C Tx/Rx Session	7
3.	MAIN WINDOW AND MENU DESCRIPTIONS	10
3.1	Main Window	10
3.2	Setup Menu	11
3.3	Add/Edit I2C Message Window - Read	12
3.4	Add/Edit I2C Message Window - Write	13
	APPENDIX A	14
1.0	Specifications	14
	APPENDIX B	16
1.0	PC System Requirements	16
	APPENDIX C	17
1.	Installing USB Driver	17
2.0	Installing Application Software	20
	APPENDIX D	21
1.0	General Information	21
1.1	Warranty	21
1.2	Thirty-Day Return Policy	21

1.3	Limitation of Liability	21
1.4	Contact Us	21

1. INTRODUCTION

The JI-300 is a versatile, easy to use, PC hosted adapter used to drive I2C communications to/from a target bus. The desktop unit can be configured to interface a variety of I2C networks. Bus parameters such as clock frequency, duty-cycle, setup and hold times, bus voltage, and pull-up resistor values can be varied. JI-300's diagnostic features including "excessive clock-stretch", "bus-not-free", and "bus contention" monitoring, as well as status reporting at the conclusion of each message transaction simplifies I2C trouble-shooting. A Windows software application manages the setup and control of the instrument. Communications and unit power is provided via a USB 2.0 connection.

Features

- Programmable SCL clock frequency from 255Hz to 3.8Mhz (20nS steps).
- Variable bus voltage from 1.50V to 5.25V (10mV steps).
- Supports Master and multi-Master operation.
- Software selectable bus pull-up resistors (16 values including open)
- Low I2C bus capacitance (<40pF typ.)
- USB 2.0 host interface
- Switched target bus voltage available at connector
- Easy to use Graphical User Interface (GUI) software.
- Create custom software applications by way of either direct or Virtual COM Port (VCP) drivers. Programming requires no in-depth knowledge of USB!
- Includes everything needed to get started – I2C Adapter unit, I2C cable, USB cable, and a CD-ROM containing application software and user's manual.

Applications

- Firmware debugging and hardware troubleshooting
- Production line testing
- Equipment repair and diagnostics

1.1 Front Panel Description

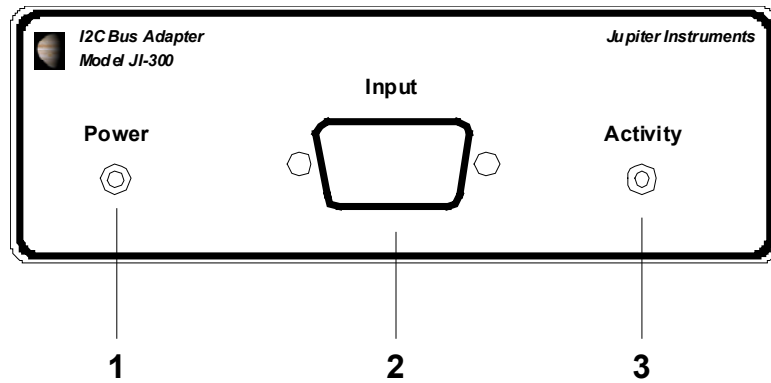

1. **Power** – Power on LED
2. **Activity** – I2C bus activity/USB port open LED.
3. **Input** – I2C probe cable jack. 9-pin, Female, D-Sub connector (AMP 745781-4)

Pin-outs: Pin 1 = SDA
 Pin 5 = GND
 Pin 6 = SCL
 Pin 8 = Vbus
 Pin 2, 3, 4, 7, 9 = No Connection

1.2 Rear Panel Description

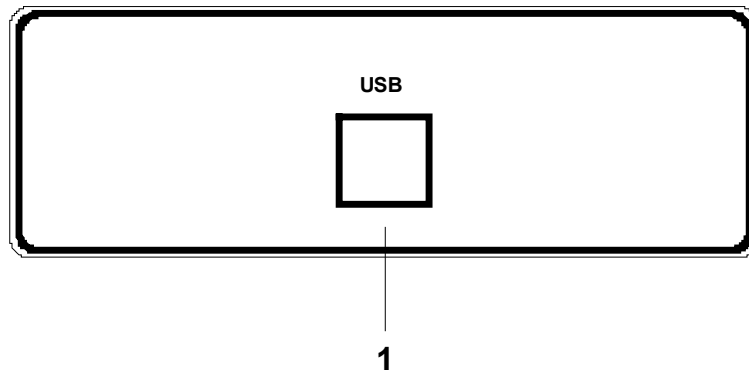

1. **USB** – Type 'B' connector (Molex 67068-0000)

2. GETTING STARTED

2.1 Software Installation

The JI-300 Host Adapter requires the installation of both a USB driver and application software. The drivers must be installed on the host PC's hard-drive. The application software, however, can be installed locally or executed directly from CD-ROM. See appendix C for detailed instructions on installing both the USB driver and JI-300 application software.

2.2 Hardware Setup

1. Connect the I2C Host Adapter unit to the host PC using 6' USB cable.
2. After a few seconds, confirm that the JI-300 is powered by verifying that the front panel PWR LED is on.

2.3 Communications Check

1. Ensure that the I2C Host Adapter unit is connected to the host PC and power is on.
2. Go to the folder C:/JI300/
3. Launch the I2C Host Adapter application by clicking I2C_Bus_Adapter.exe.
4. Verify that the main I2C Host Adapter window is displayed as shown in figure 1.

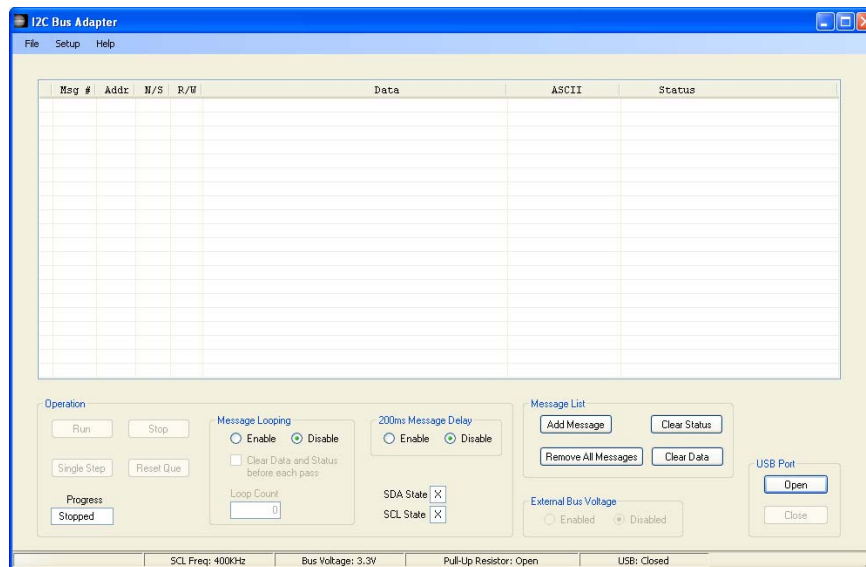

Figure 1. I2C Host Adapter Main Window

If an error occurs and the window does not appear, begin by verifying that the .NET Framework is installed. To do this, click **Start** on your windows desktop, select **Control Panel**, and then double-click the **Add or Remove Programs** icon. When the window appears, scroll through the list of applications. If you see the .NET Framework 3.0 listed, the latest version is installed. If not listed, go to <http://msdn2.microsoft.com/en-us/netframework/aa569263.aspx> for instructions on downloading and installing the .NET Framework.

5. At the main window, open a USB port by clicking the **Open** button in the USB Connection group.
6. Ensure an open USB port by confirming an open port status.
7. At the menu bar, open the About message box by selecting **Help** then **About**.
8. Verify that the version numbers for the **HW Version x.x** and **VHDL Version x.x** are valid (i.e. 1.0, 2.1, etc.) If a question mark (?) or some other character appears, an error has occurred.
9. If no errors have occurred (or if errors have been resolved) the Communications Check has passed.

2.4 I2C Tx/Rx Session

For this exercise, a target slave device (included with the JI-300 kit) or I2C network with at least one slave device will be needed. Power to the device or network can be supplied by either the I2C target or JI-300 Adapter. The following steps are for use with the test M24C04 I2C target device.

1. Ensure that the I2C Host Adapter unit is connected and power is on. (Section 2.2 Hardware Setup)
2. Ensure that the I2C Host Adapter application is running and the USB port is open. (Section 2.3 Communications Check)
3. Connect the I2C probe cable to the D-sub connector on the I2C Host Adapter front panel.
4. Locate the test M24C04 I2C (4Kbit Serial I2C EEPROM) target device supplied with the kit. (See Figure 2)
5. Connect the four I2C bus probes (SDA, SCL, PWR, and GND) to the I2C target device. (See Figure 3)

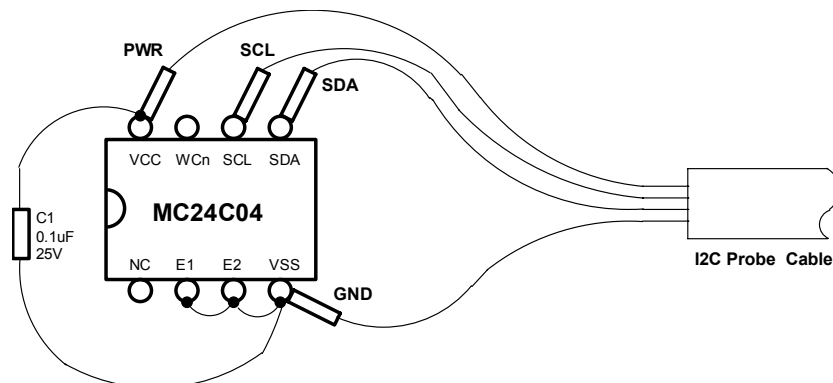

Figure 3. Connections to M24C04 I2C target test device

6. At the main window, click the **Add Message** button to begin adding I2C messages to the list.

7. The Add I2C Message window is now displayed. (See Figure 4)

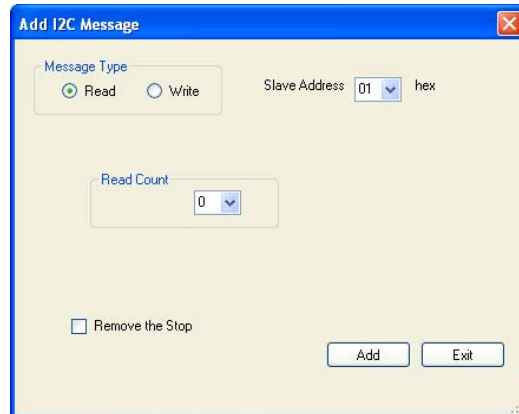

Figure 4. Add I2C Message Window

8. Add the following data to create a write message:

1. **Message Type:** Write (Note: The Message Window will change from a Read to Write when the Write Message Type is selected)
2. **Slave Address:** A0
3. **Write Data (1):** 00
4. **Remove the Stop:** Check Box

9. Click **Add** to add the message to the message list.

10. Next, add a read message.

11. Add the following data to create a read message:

1. **Message Type:** Read
2. **Slave Address:** A1
3. **Read Count:** 16
4. **Remove the Stop:** un-Check Box

12. Click **Add** to add the message to the message list, followed by **Exit**.

13. Verify that two messages (a read and write) have been added to the Message List. (See figure 5)

MSG #	Addr	N/S	R/W	Data	ASCII	Status
001	A0	*	W	10		
002	A1		R	XX XX XX XX XX XX XX XX XX XX XX XX XX XX XX XX		

Figure 5. I2C Messages

14. At the Main Window menu bar, open the setup menu by selecting **Setup**, then **Setup Menu**.

15. The Setup menu is now displayed (See Figure 6)

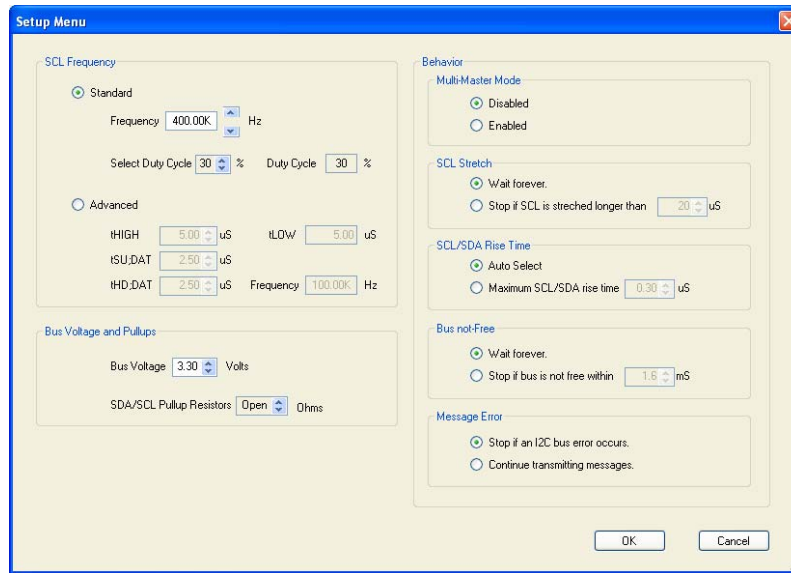

Figure 6. Setup Menu

16. At the Bus Voltage grouping, select a 1K ohm bus pull-up resistor by clicking the up/down buttons.
17. Click **OK** to save the selection and close the Setup Window.
18. At the main window, turn-on the external bus voltage by clicking **Enable** in the External Bus Voltage grouping.
19. Enable Message Looping by clicking **Enable** in the Message Looping grouping.
20. Now, begin an I2C session by clicking **Reset Que**, followed by clicking **Run** in the Operation grouping.
21. Verify the following actions:
 1. The message "Success!" is in the status columns for both messages.
 2. The text "Hello world!" is in the ASCII column of the read message.
 3. The asterisk cursor quickly moving back-and-forth between the two messages.

3. MAIN WINDOW AND MENU DESCRIPTIONS

3.1 Main Window

The I2C Host Adapter *Main Window* is shown in Figure 7.

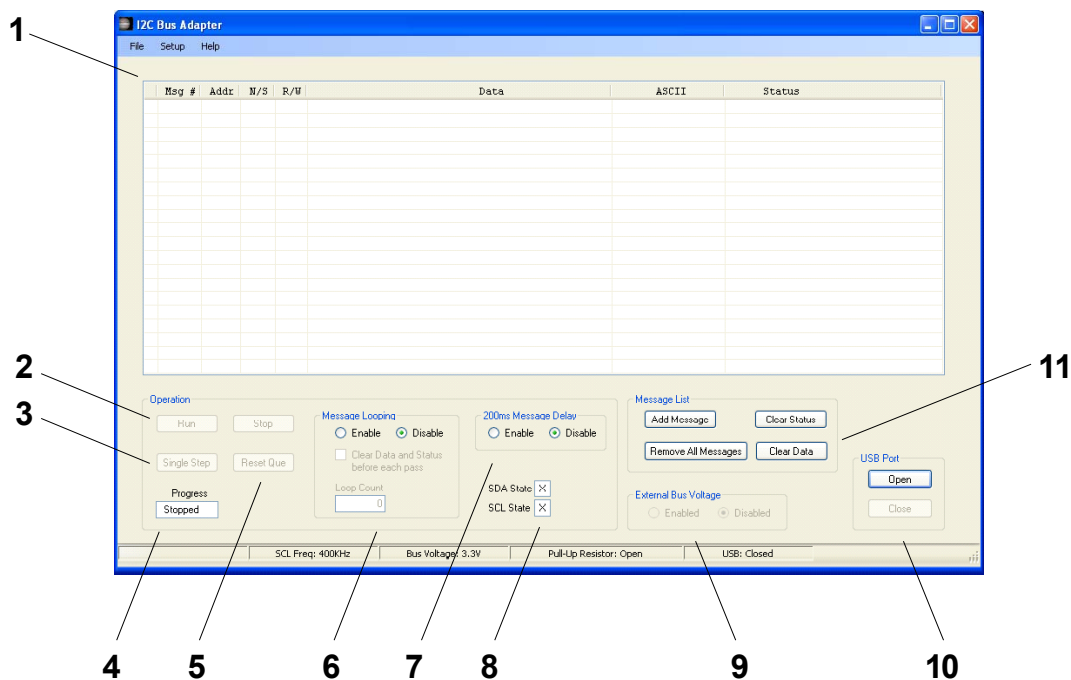

Figure 7. I2C Host Adapter Main Window

1. **Message List** – I2C messages are stored here. Messages are added via the **Add Message** button. To **Insert, Edit, or Delete** an existing message, double-click the message number.
2. **Run/Stop** – These buttons control the transmission of I2C messages. The **Run** button initiates a session where by I2C messages stored in the message list are squelchy executed. The session starts at the cursor position and ends either by the execution of the lasted message in the list or by clicking the **Stop** button.
3. **Single Step** – This button is used to transmit a single I2C message.
4. **Progress** – Status of the current session is displayed here.
5. **Reset Que** – Clicking this button moves the cursor to the first message in the message list.
6. **Message List Looping** – This group provides control and monitoring of the message list looping function. When **Enabled**, a session will cyclically execute all I2C messages stored in the message list when a session is started. A **Clear Data & Status** check box provides the option of clearing both Data and Status columns at the beginning of each loop pass.
7. **200mS Message Delay** – This function, when **Enabled**, inserts a small delay (approx. 200ms) between each message transmission.
8. **I2C Bus State** – The present state of the SCL and SDA signals is displayed here.
9. **External Bus Voltage** – Control (On/Off) of the external bus voltage (Vbus) is performed here.

10. **USB Port** – Open/Close USB port from this area.

11. **Message List** --

- a. **Add Message** – Clicking this button will either add a Read or Write message to the Message List. Messages will be appended to the bottom of the list.
- b. **Clear Data** – Clicking this button will remove all read data from the Message List.
- c. **Clear Status** – Clicking this button will remove all status comments from the Message List.
- d. **Clear Message List** – Clicking this button will remove all messages from the Message List

3.2 Setup Menu

The *Setup Menu* provides a convenient means of configuring and maintaining an I2C hardware setup (See Figure 8.)

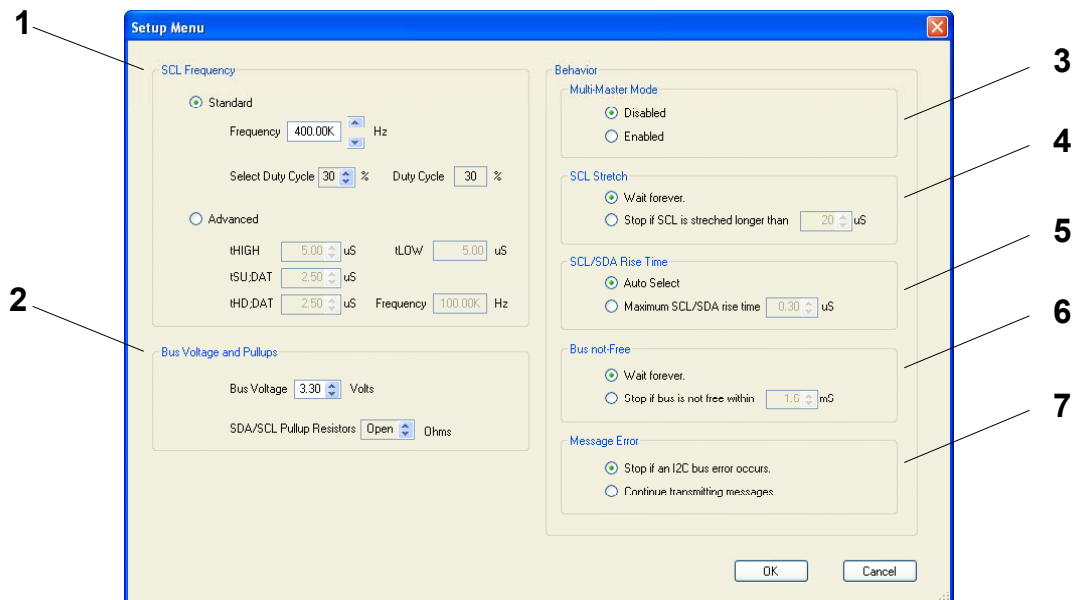

Figure 8. Setup Menu

1. **SCL Frequency** – Two methods are provided to configure the SCL Clock: **Standard** and **Advanced**. When selecting **Standard**, Frequency and Duty cycle data is entered and the tHIGH, tSU,DAT, and tHD,DAT values that comprise the SCL waveform are automatically calculated and loaded. Note that tSU,DAT, and tHD,DA values are held nearly equal (+/- 1 bit). If a unique SCL waveform is desired, the **Advanced** mode is selected. In this mode tHIGH, tSU,DAT, and tHD,DAT data is entered directly. The resultant SCL frequency and tLOW value is then calculated and displayed.
2. **Bus Voltage and Pull-ups** – The I2C Bus voltage and SDA/SCL pull-up resistor values are entered here.
3. **Multi-master Mode** – JI-300 multi-master mode is enabled/disabled here.

4. **SCL Stretch** – During a Slave SCL stretch event, the behavior of the JI-300 can be configured to:
 - a. Wait indefinitely on a SCL stretch event – **Wait Forever** selection
 - b. Stop if the selected SCL stretch value is exceeded.
5. **SCL/SDA Rise Time** – The maximum expected rise-time value for either the SCL or SDA signal is entered here. I2C physical layer parameters such as pull-up resistors, bus voltage, and bus capacitance can affect rise-time. Two methods are provided to configure the rise-time:
 - a. Nominal I2C system – **Auto Select** selection
 - b. Specialized I2C system – Rise-time value is entered
6. **Bus not Free** – The behavior of the JI-300 can be configured to either wait indefinitely for a “bus free” condition or stop if a “bus free” condition is not available within a specified time.
7. **Message Error** – In the event of a bus error during an I2C transmission session, the behavior of the JI-300 can be configured to:
 - a. Stop all transmissions
 - b. Note the error and continue transmitting

3.3 Add/Edit I2C Message Window - Read

The *Add/Edit I2C Message Window - Read* is used to both edit and add new Read messages to the Message List (Figure 9.)

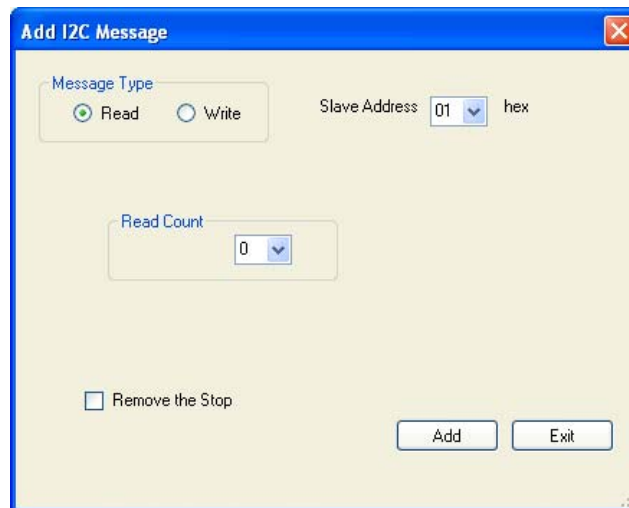

Figure 9. Add/Edit I2C Message Menu - Read

3.4 Add/Edit I2C Message Window - Write

The *Add/Edit I2C Message Window - Write* is used to both edit and add new Write messages to the Message List (Figure 10.)

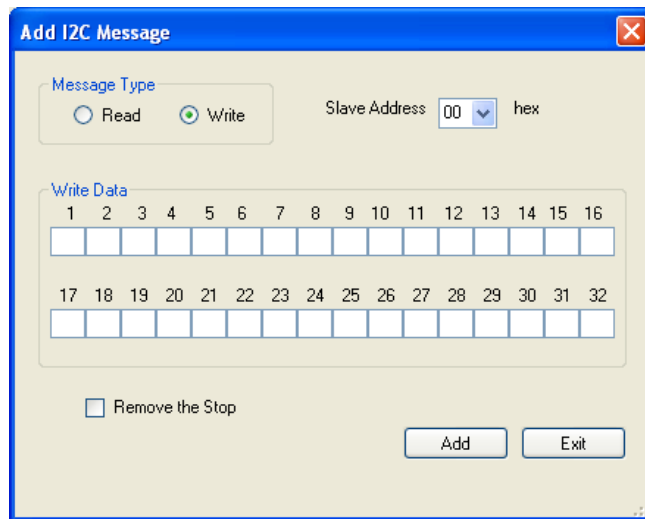

Figure 10. Add/Edit I2C Message Window - Write

APPENDIX A

Edition

1/19/2008

Version 1.1

1.0 Specifications

Hardware

PC Interface

Type: USB 2.0
Connector: Standard Type B Socket

Power

USB port: 5V @ 300mA (max) Note that all power is supplied by the USB port.

I2C Interface

Connector: Standard 9-Pin, D-sub, Female

Pin-outs: Pin 1 = SDA
Pin 5 = GND
Pin 6 = SCL
Pin 8 = Vbus
Pin 2, 3, 4, 7, 9 = No Connection

SCL/SDA Bus Voltage (Vbus) Range: Programmable - 1.50V to 5.25V (10mV steps) +/-2%

Input Threshold: VIL: 0.2Vbus (typical)
VIH: 0.7Vbus (typical)
VTH: 0.1Vbus (typical)

Input Voltage Range: -0.3V to 6.0V (operational)
-5.0V to 10.0V (maximum rating)

SCL Frequency: Programmable –
Standard: 7.0KHz to 4.0MHz
Advanced: 254Hz to 4.0MHz (20nS steps)

SCL/SDA Sink Current: 27mA (typical) short-circuit protected

SCL/SDA Pull-up Resistors: Programmable – 273 to 4.99K ohms & Open (16 selections) +/-3%

Input Capacitance: < 40pF without test cables

External Bus Voltage: Switched Vbus available to power external I2C target. Current limited to 90mA (typical)

LEDs

Power:	Power-On (USB device enumeration)
SCL/SDA Activity:	LED provides two functions: <ul style="list-style-type: none">• I2C Bus activity• Software “Open” success - Indicated by LED blinking three times when the software application successfully opens a USB connection unit.

Enclosure

Dimensions:	4.1” x 1.1” x 5.5”
Material:	Vinyl-clad steel cover with an extruded aluminum base.
Weight:	0.9 lbs.

General

I2C bus

Address Format:	7-bit
Bus Modes:	Master & Multi-Master
SCL Programmable Parameters:	<ul style="list-style-type: none">- tSU;DAT (20nS steps)- tHD;DAT (20nS steps)- tHIGH (20nS steps)

Data Transfer

Tx/Rx Status Report:	<ul style="list-style-type: none">- Bus not-Free condition- Clock Stretch occurrence- SDA signal contention (Master Mode)- Loss of arbitration (Multi-Master mode)- Missing ACK
Behavior Setup:	<ul style="list-style-type: none">- Bus not Free (programmable max. time)- Clock Stretch (programmable max. time)- Repeated Start (Selectable)

APPENDIX B

1.0 PC System Requirements

- Microsoft Windows 98*, 2000*, and XP

*These OS require the .NET framework. If installation is required, go to <http://msdn2.microsoft.com/en-us/netframework/aa569263.aspx>

- USB 2.0 port
- CD-ROM drive
- 10 MB Free hard disk space

APPENDIX C

1. Installing USB Driver

Two types of drivers will be installed: Virtual COM Port (VCP) and Direct Drive (D2XX). The VCP driver allows control of the JI-300 adapter via ASCII serial commands sent using a terminal emulation program such as Windows Hyper Terminal. The D2XX driver allows direct access to a USB device via a DLL interface. In this installation, both drivers will be installed separately. (For additional driver information, please visit <http://www.ftdichip.com/FTDrivers.htm>)

1. Temporarily disconnect the host PC from the Internet. (Simply remove the network cable from the PC)
2. Insert the JI-300 CD-ROM into the computer's CD drive.
3. Connect the JI-300 unit to a spare USB port.
4. Now, verify that the "Found New Hardware Wizard" window is displayed as shown in Figure 1.



Figure 1. Found New Hardware Wizard Window

5. Select "No, not at this time" from the options, and then click "Next".

- At the “Found New Hardware Wizard” window (Figure 2), select “Install from a specific list or location (Advanced)”, and then click “Next”.

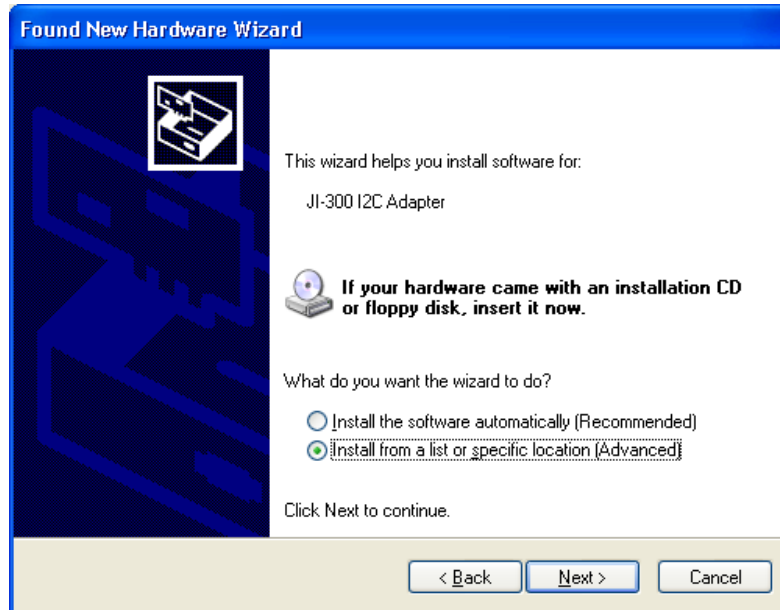

Figure 2. Found New Hardware Wizard Window #2

- At the “Found New Hardware Wizard” window (Figure 3), select “Search for the best driver in these locations” followed by “Search removable media (floppy, CD-ROM...)”. Click Next.

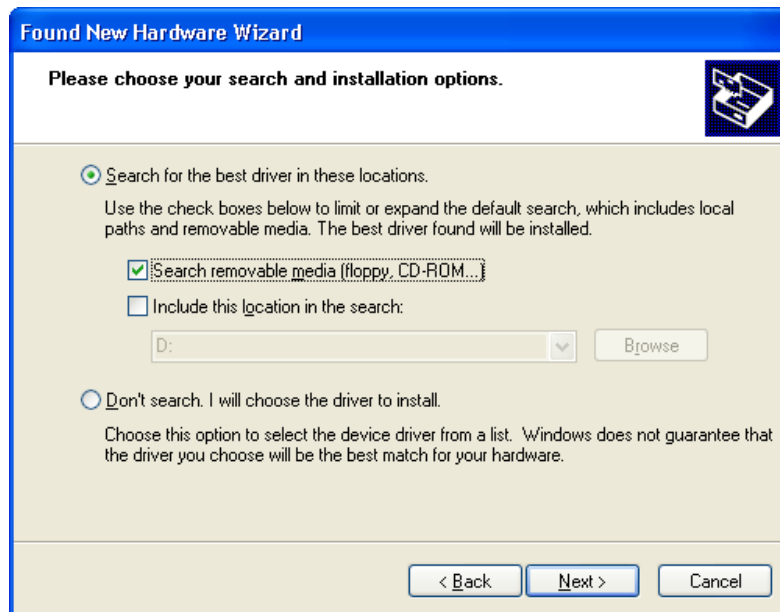

Figure 3. Found New Hardware Wizard Window #3

8. A window is now displayed showing the driver software being located and then copied (Figure 4).

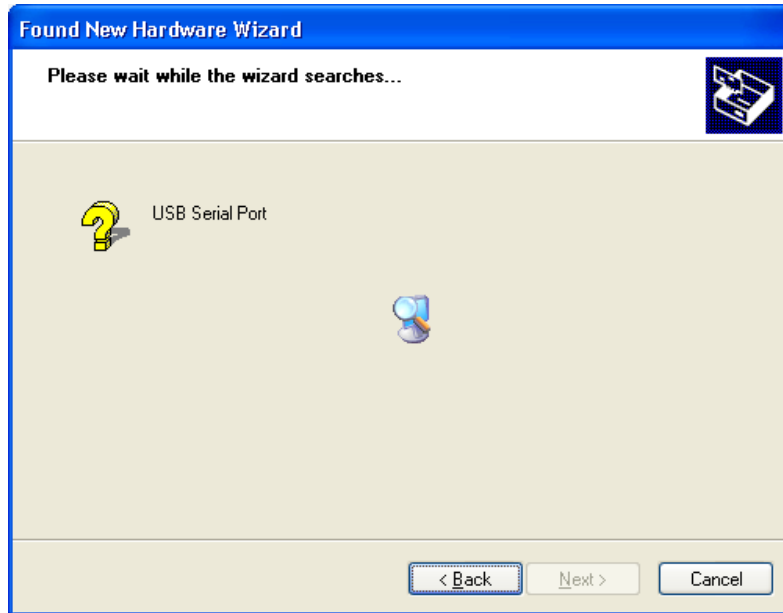

Figure 4. Driver Coping Window

9. A window indicating that the installation was successful should now be displayed (Figure 5).



Figure 5. Installation Success Window

10. The D2XX driver is now installed. Click Next.
11. Repeat steps 5 through 11 to install the VCP driver.
12. The installation is now complete.

2.0 Installing Application Software

The JI-300 application software can be installed either locally on the host PC's hard drive (C:) or executed directly from CD-ROM. To install locally:

1. Insert the CD-ROM into the host PC's CD drive.
2. Using Windows Explorer, copy the JI300 folder containing the JI-300 executable (and DLLs) from the CD-ROM to a convenient location on the PC's hard-drive.
3. Software installation is now complete.

APPENDIX D

1.0 General Information

1.1 Warranty

The equipment is warranted for one year from date of purchase against defects in materials or workmanship. Jupiter Instruments reserves the right to repair or replace products at its own and complete discretion. Customer must obtain from Jupiter Instruments a Return Authorization Number (RMA) prior to returning any products to Jupiter Instruments. Products returned under this Warranty must be unmodified and in original packaging. Jupiter Instruments reserves the right to refuse warranty repairs or replacements for any products that are damaged or not in original form.

The customer is responsible for the shipping and insurance cost arising from the return of products to Jupiter Instruments. Jupiter Instruments will return all in-warranty products with shipping cost prepaid.

1.2 Thirty-Day Return Policy

Customers may return Jupiter Instruments products for a full refund if Jupiter Instruments is contacted within thirty days of the customer's receipt of the product. Customer may return Jupiter Instruments products for credit, exchange, or a refund. Customer must obtain from Jupiter Instruments a Return Authorization Number (RMA) prior to returning any products to Jupiter Instruments. Products must be returned unmodified and in original packaging. Jupiter Instruments reserves the right to refuse return rights for any products that are damaged or not in original form. Volume orders may be subject to a significant restocking fee.

1.3 Limitation of Liability

Jupiter Instruments' liability shall be limited to the repair or replacement of defective products in accordance with the Jupiter Instruments limited warranty.

Jupiter Instruments shall not be liable for any incidental, special or consequential damages for breach of any warranty, expressed or implied, directly or indirectly arising out of Jupiter Instruments' sale of merchandise, including any failure to deliver any merchandise, or arising out of customer's installation or use, whether proper or improper, of the product, separately or in combination with other equipment, or from any other cause. Use the JI-210 and/or JI-300 at your own risk.

Products sold by Jupiter Instruments are not authorized for use as critical components in life support devices or systems.

1.4 Contact Us

- Address: Jupiter Instruments
25108 Marguerite Pkwy Suite, B #109
Mission Viejo, CA 92692-2400

- Email: Sales@Jupiteri.com
Tech@Jupiteri.com

- Phone: Sales and Information: (949)-716-0154

- Website www.Jupiteri.com